



BeamLink-Quad Plus 1U Rack

4-Channel Wireless Video Transmission System

EU Environmental Protection

Waste electrical products should not be disposed of with household waste. Please recycle where facilities exist. Check with your local authority or retailer for recycling advice.



SHENZHEN CRYSTAL VIDEO TECHNOLOGY CO.,LTD

ADD: Unit 05-06, Floor 24, Changhong Science & Technology Mansion, Keji 12th Road South, High-tech Industrial Park, Nanshan District, Shenzhen, P.R. China

Post code: 518057

www.cv-hd.com

Tel: +86-755-29977913

E-mail: Sales@cv-hd.com

Facebook: @crystalvideowireless Instagram: cvwtechnology

USER MANUAL

This user manual applies to:

Transmitter: 7060*4

Receiver: 6689+3066*1

Version: 1.0

2023. 2. 8

Contents

Caution	01
About the User Manual	02
Product Overview	02
Product Highlights	02
Packing List	03
Interfaces and Buttons	04
Transmitter	04
Receiver	06
Product Installation	10
Installation of Transmitter	10
Installation of Receiver	12
OLED Display Screen	14
Functional Instructions	16
RTSP Streaming Mode Operation	18
Video Parameter Settings	21
Upgrade	22
System Connectivity Diagram	25
Product Specifications	26
Important Reminders	27
Troubleshooting	31

Caution

Thank you for purchasing CVW's wireless HD video transmission system. Before using this product, please carefully read the following reminders.

- * Avoid exposing this product to direct sunlight for long time or using it in dusted places
- * You must use this product within its temperature and humidity range.
- * Avoid using this product when it is exposed to vibration and a strong magnetic field.
- * Avoid contact of conductive materials with the interior of the product.
- * Do not open this product's enclosure without guidance from a professional at our company.

Important Reminders

- * When installing the magic arm, please fix the transmitter in a direction you want, then twist the magic arm to fix it on the camera. If you rotate the transmitter to fix it, the magic arm will not be easily demounted from the transmitter.
- * Since the RS232 and Tally interfaces are non-standard physical interfaces, if you need these functions, please contact our sales staff to confirm.

About the User Manual

This instruction manual provides a detailed introduction to this product's specifications and an explanation of its interfaces, usage, reminders, and a troubleshooting guide.

Before using this product, please carefully read this instruction manual. If you have any questions or concerns while using this product, please contact us or our suppliers as soon as possible.

Product Overview

BeamLink-Quad Plus 1U Rack is a multi-channel wireless video transmission system based on a 5GHz band that supports 4-channel wireless video and audio transmission, Tally, and pan-tilt-zoom (PTZ) camera control, with video resolution up to 1080p/60Hz. It is widely used in live streaming, TV and filming, multimedia education, etc.

Product Highlights

■ Four channels of transmission only occupy one wireless channel

Supports simultaneous four-channel video and audio signals transmission, and each video channel's highest resolution can reach 1080p/60Hz. These channels use the same wireless channel, greatly saving spectrum resources.

■ High-quality and low-latency video frame

Supports HD-SDI & 3G-SDI input and output, supports HDMI full HD input and output, highest resolution can reach 1080p/60Hz. Compared with H.264 technology, H.265 technology offers higher color reproduction, showcasing the image more colorful.

■ Beamforming

4* 4 MIMO and Beamforming technologies make the wireless beams more concentrated, signal-to-noise ratio higher, which result in a farther transmission distance and a stronger interference immunity.

■ Point-to-Point Mode and RTSP Streaming Mode

The system supports point-to-point mode and RTSP streaming mode working simultaneously, which means that HDMI, SDI, and LAN ports can output video signals at the same time. In so doing, this solution can be widely applied to different scenarios.

■ RS232/422 Transparent Transmission

The RS232/422 port can support the pan-tilt-zoom (PTZ) camera control.

Packing List



Transmitter * 4



Antenna * 20



Double Ball Head Magic Arm * 4



SDI Cable * 4



D-Tap to 2-pin LEMO Cable*4



Receiver * 1



WiFi Adapter *1



RS232 Cable * 5



Power Adapter * 1

*All the transmitters come with an NP-F battery holder and are preinstalled with a V-mount connector.

Interfaces and Buttons

TX: 7060

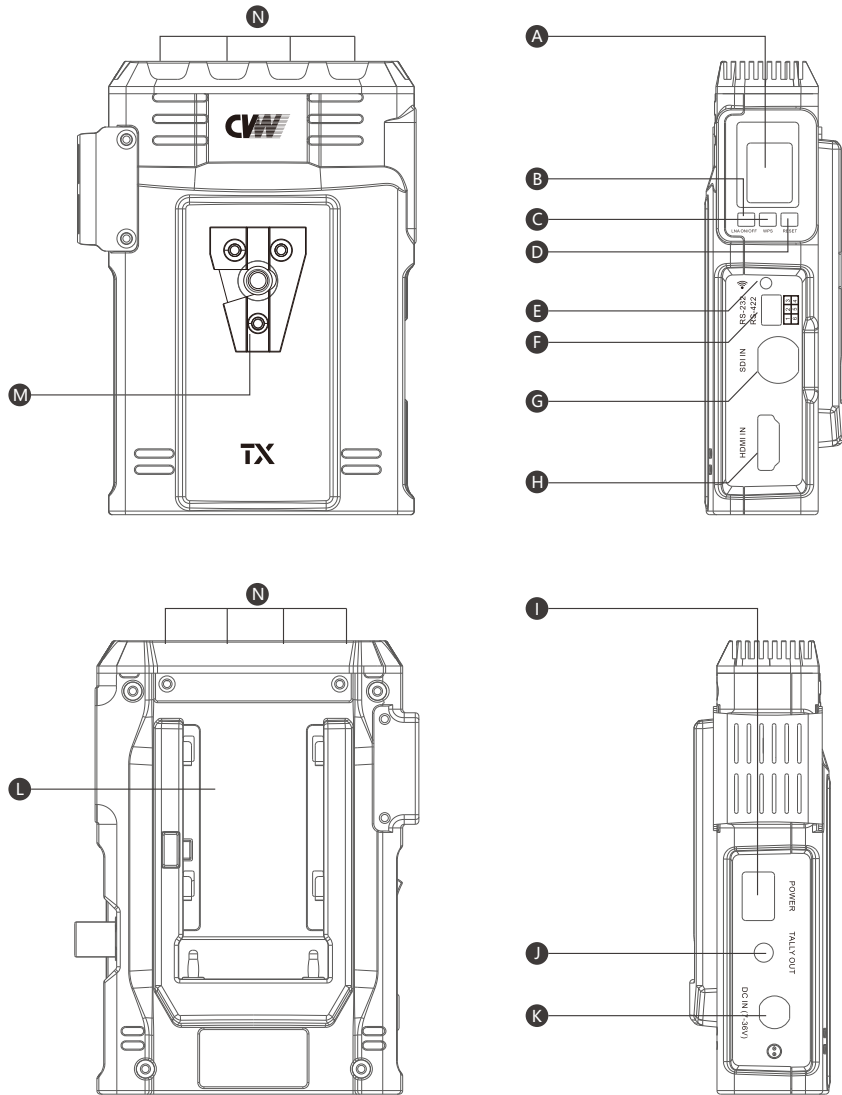

Introduction to Transmitter's Interfaces and Buttons

Name	Function
A	OLED display
B	LNA ON/OFF button: High-gain and Low-gain mode switching
C	WPS button: pairing
D	Reset button
E	Network status warning light, yellow light flickers slowly: network connecting; yellow light is on : network connected; red light flicker quickly: low battery.
F	RS232/422 interface
G	SDI input
H	HDMI input
I	Power switch
J	Tally output
K	LEMO DC input
L	Battery slot
M	V-mount slot
N	Antenna connectors

RX: 6689

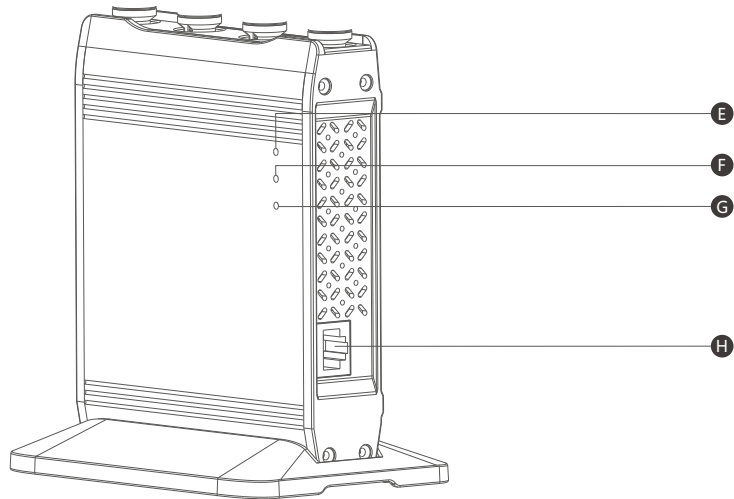
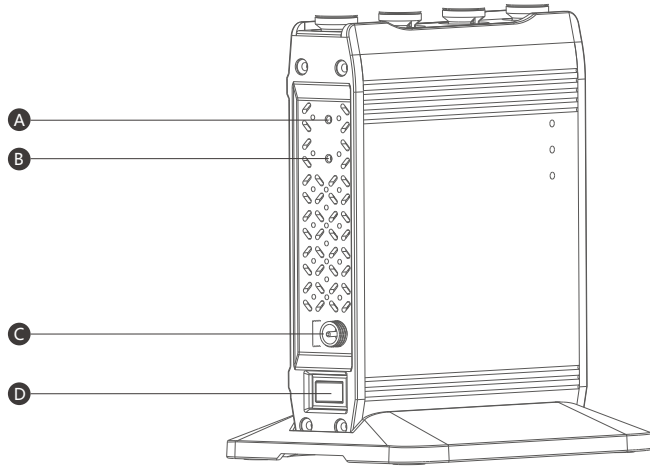

Introduction to Receiver's Interfaces and Buttons

Name	Function
A	Reset button
B	WPS button, pairing
C	DC input
D	Power switch
E	Power indicator: light on: operating normally; light off: power off or abnormal
F	Network status indicator light: flash: fail to connect the network; solid: network connected
G	Mode indicator light
H	LAN port

RX: 3066

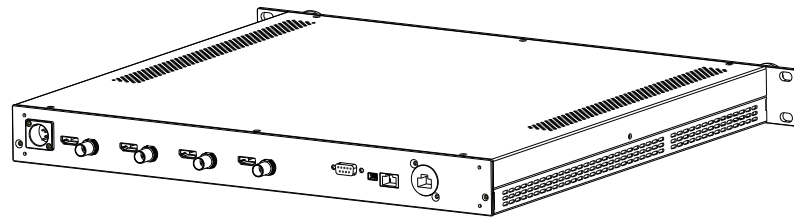
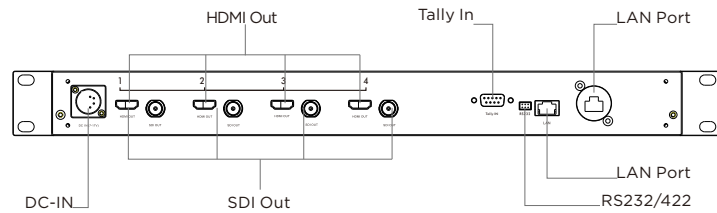
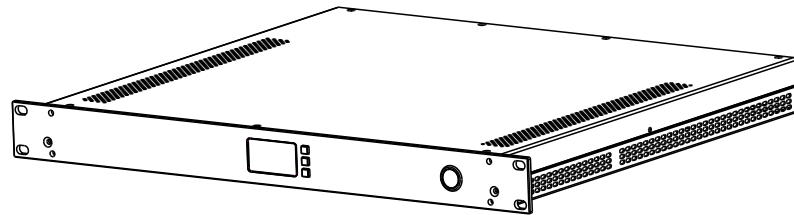
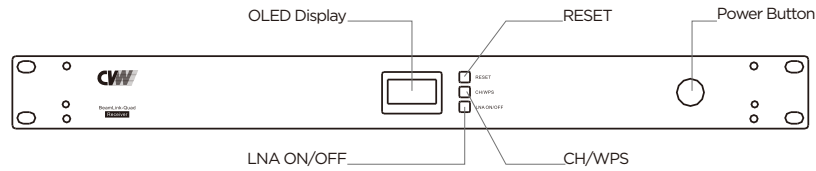

Introduction to Receiver's Interfaces and Buttons

Function	Operation	Instruction
Channel switch	Short press the CH or WPS button	Once the channel is switched to a different channel on the receiver, the transmitter also will go with it. And the channel will be displayed on the screen of the transmitter and receiver.
Low gain and high gain mode switch	Long press the "LNA ON/OFF" button for 3 seconds	The low gain mode has a good interference performance, and it is used mainly in a complex and short-distanced environment (the screen displays "L"). Compared with the low gain mode, the high gain mode shows a weak interference performance, so it is used in a wide and long-distanced environment (the screen does not display "L").
Pairing	Long press the "CH/WPS" button for 3 seconds	Once pairing is enabled, "WPS" will be displayed on the transmitter and receiver's OLED screen. Once they pair with each other successfully, "WPS" will be disappeared on the OLED screen. Please note that the critical point to pair them successfully is that both must be in a pairing situation.
The displayed method of OLED screen	Short press the "LNA ON/OFF" button for 1 second	Horizontal screen mode or vertical screen mode
Restarting one of the four channels on the receiver	Short press the "RESET" button to choose the channel you want to restart, then long press it for 3 seconds to enable this function.	Once restarting is enabled, "RESET" will be displayed on the OLED screen. Once it is restarting successfully, "RESET" will disappear.

Product Installation

Installation of Transmitter

1. Attach the antennas to the transmitter's antenna connectors. To achieve even better range performance, all antennas should be arranged in a fan shape. (as depicted in the diagram)

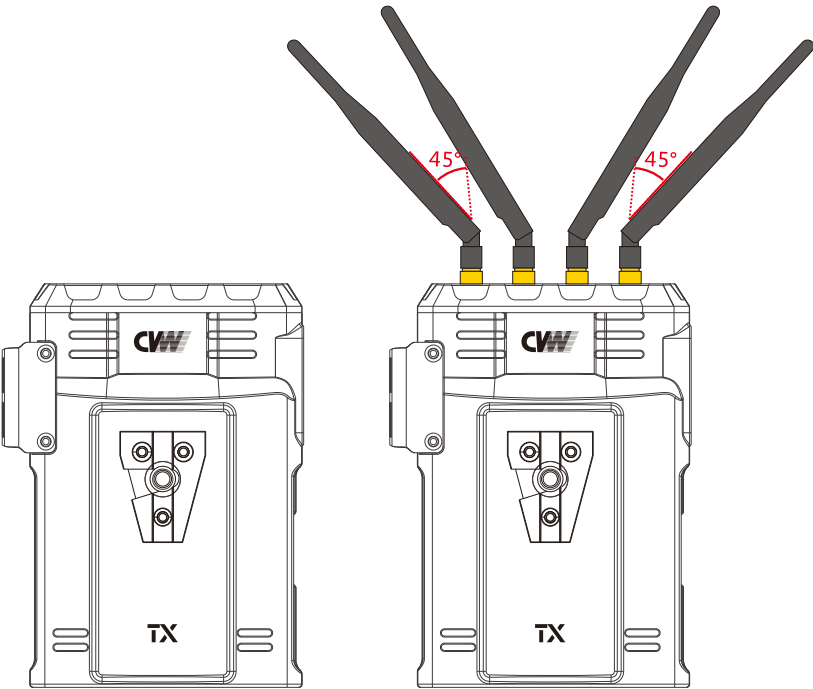

2. Mount the transmitter on a camera through the screw hole or the V-mount plate. It is recommended to hold the camera in a height where it is at least 1.5-2 meters above the ground. If using multiple transmitters simultaneously, please keep them at least 1 meter apart. (as depicted in the diagram)

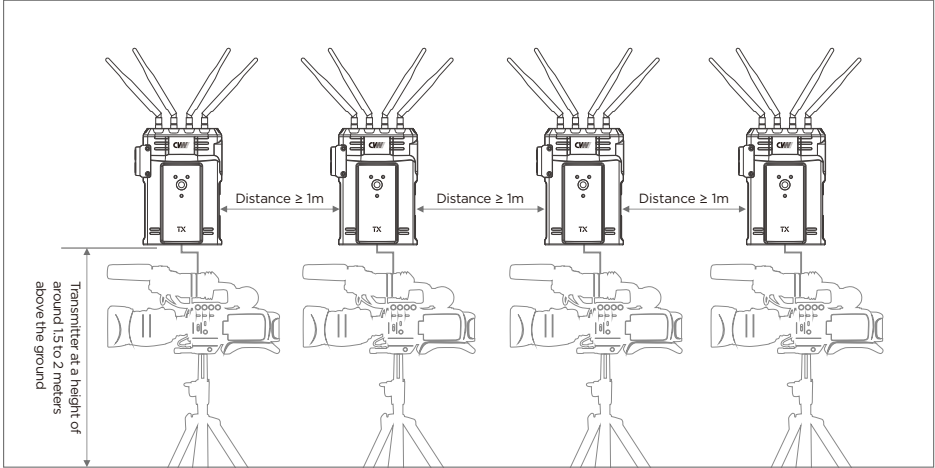

3. Please connect the transmitter to the camera with an SDI or HDMI cable. (as depicted in the diagram)

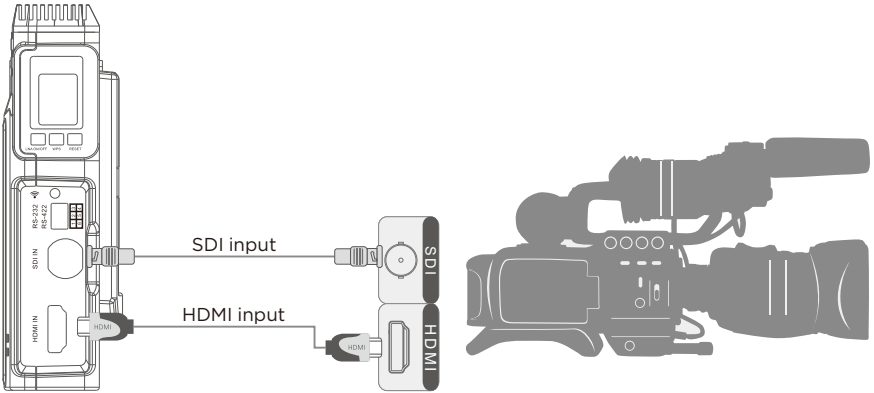

Installation of Receiver

1. Mount the WiFi adapter on a tripod, then connect it to the receiver with a network cable.

*Attach the antennas to the WiFi adapter's antenna connectors. To achieve even better range performance, all antennas should be arranged in a fan shape. (as depicted in the diagram)

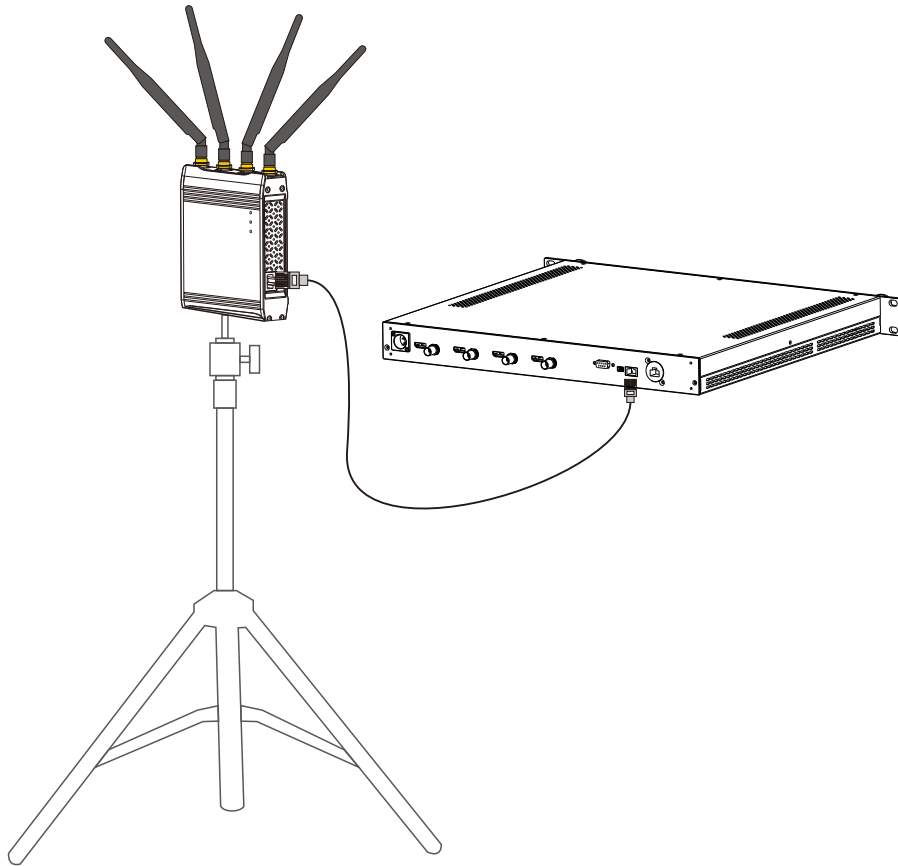

2. Please connect the receiver to the switch console or monitor with the SDI or HDMI cable(s). (The receiver supports 4 SDI outputs and 4 HDMI outputs)

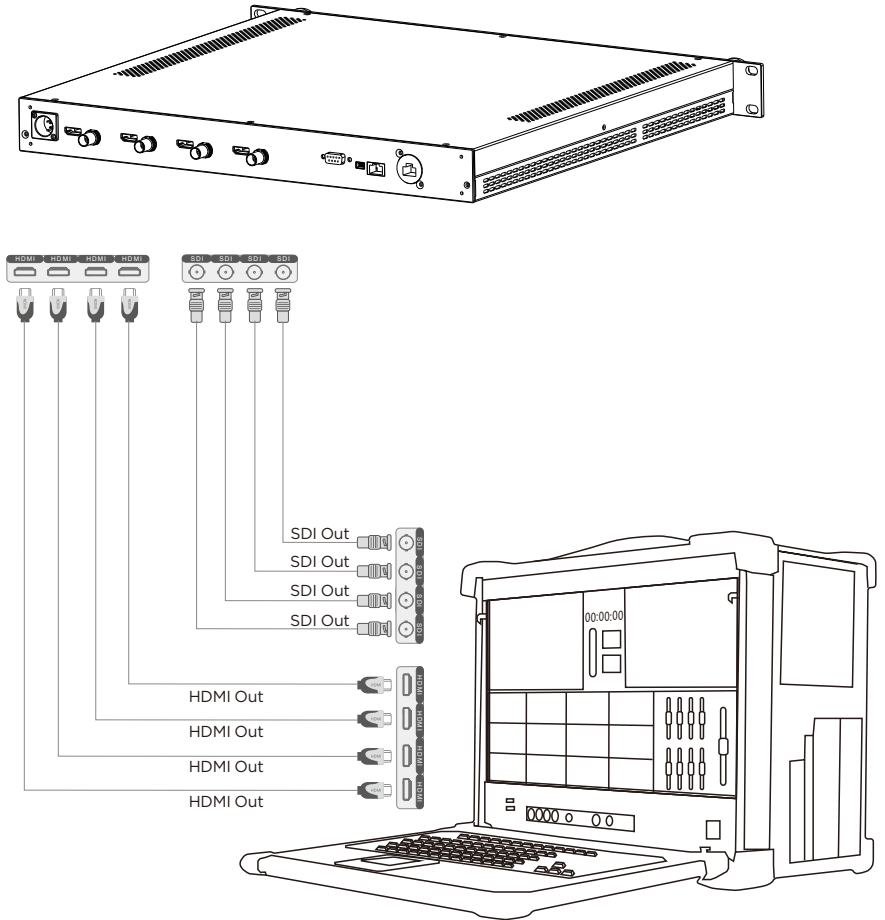

OLED Display Screen

TX:7060

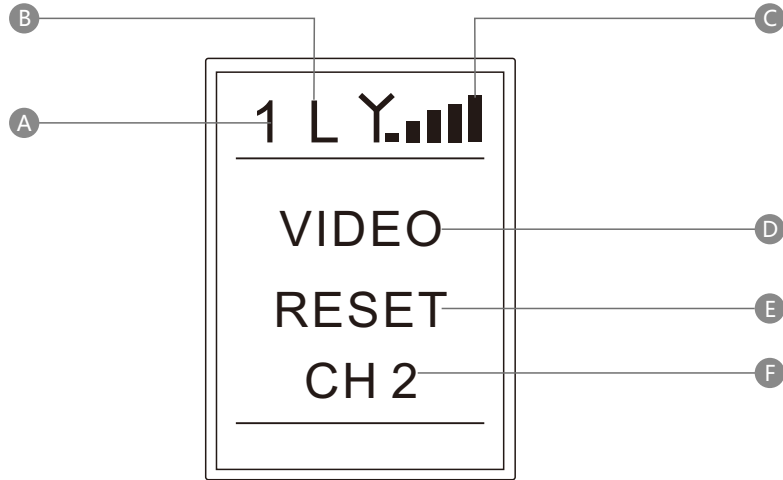

Name	Function
A	Transmitter ID: four transmitters are numbered 1, 2, 3 and 4 respectively
B	Gain mode: low gain mode (the screen displays “L”) and high gain mode (the screen does not display “L”)
C	Signal icon: video signal strength status
D	WPS: pairing
	Video: video signal input connected
E	Reset: the device is resetting
F	CH*: display current channel

RX:3066

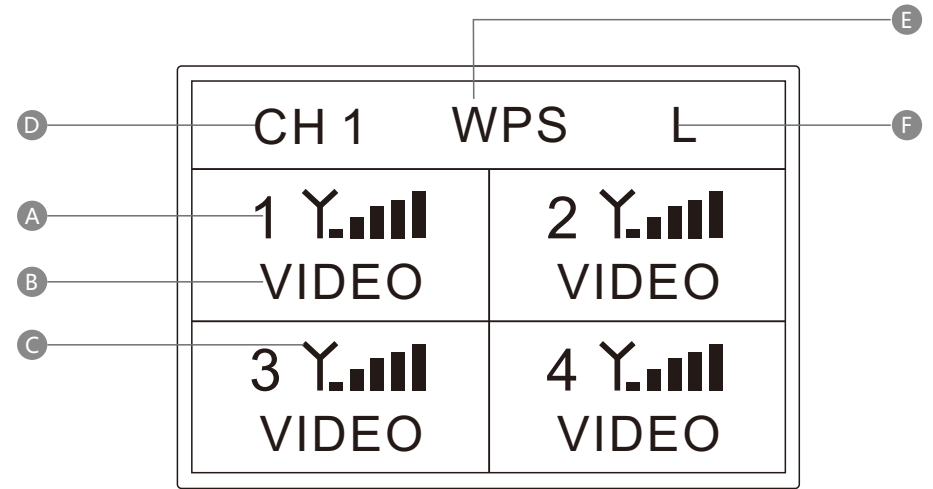

Name	Function
A	The corresponding transmitter ID: numbered 1, 2, 3, 4 respectively
B	Video: video signal input connected
C	Signal Icon: video signal strength status
D	Channel: display current channel
E	WPS: in pairing status
F	Gain mode: low gain mode (the screen displays “L”) and high gain mode (the screen does not display “L”)

Tally Function Instructions

Important Reminders:

This system's Tally function interface is factory customized. If you need this function, please contact our sales staff to confirm the pinout definition of its docking device and the type of device's interface.

- Plug the Tally light into the transmitter's Tally output port, and then connect the switch console to the receiver's Tally input interface with the customized Tally light cables. Once all the connections have been completed, the switch console can control the four transmitters' Tally lights. In so doing, the receiver as a low-level trigger will be connected to the switch console. The PGM or PVW signal will be sent to the transmitter from the switch console. Then the transmitter end's Tally light will be turned on .
- The transmitter and receiver's Tally interfaces : the transmitter's Tally interface is a standard 3.5 mm headphone jack and the receiver's Tally interface is a DB9 female socket.

Tally Light Output Interface

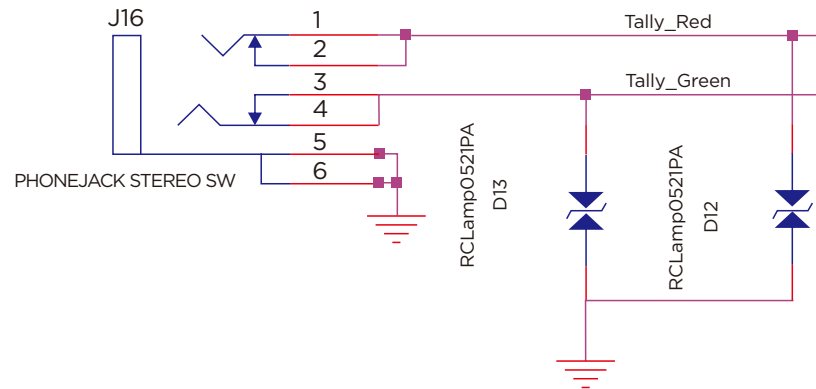

Tally Input Interface: DB9 Female Socket

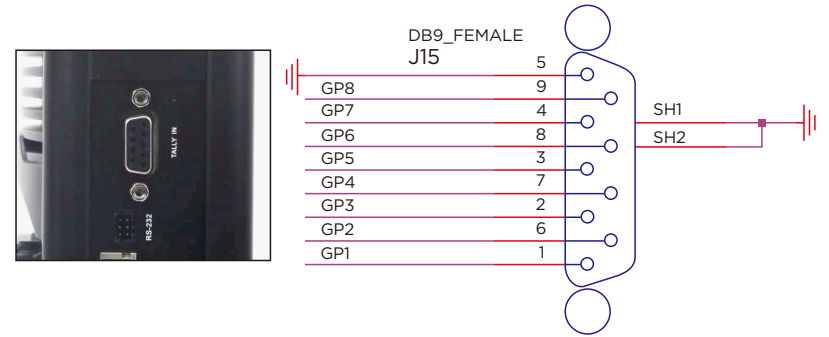

RS232/RS422 Transparent Transmission

Important reminder: The following connector is RS232 by default.

Since there are different RS232/422 interfaces for each switch console on the market, and each data signal definition of the interface is different too. If you need RS232/RS422 function, please contact our sales staff to confirm and provide them with the model number of PTZ camera and switch console or the pinout definition of RS232/RS422 interfaces. It will make us easy to customize the RS232/RS422 cables for you. Moreover, the baud rate will be set ready before delivery.

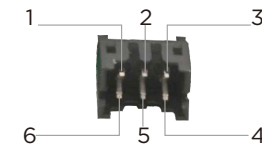

Pin NO.	RS232		RS422	
	Name	Description	Name	Description
1	NC	NC	RXD-	Receive data RX-
2	TXD+	TX data signal	NC	NC
3	NC	NC	TXD-	Transmit data TX-
4	NC	NC	TXD+	Transmit data TX+
5	GND	GND	GND	GND
6	RXD+	RX data signal	RXD+	Receive data RX+

Attached: Baud rate settings

Log in to the motherboard parameter settings page to modify the baud rate settings. For the specific operating steps, please refer to "Video Parameter Settings".

RTSP Streaming Mode Operation

Using RTSP streaming mode needs software decoding, which means images are transmitted through the receiver's LAN port to streaming media software to decode and display. Moreover, there are many kinds of streaming media existing. The following description takes VLC media player for example. Once the transmitter and receiver are connected, the transmitter's network indicator will be turned on, and the receiver's OLED screen will display the signal status. Then connect transmitters to the video sources, and connect the receiver to RTSP streaming devices through a LAN port.

Take VLC media player for example, after opening VLC, choose "Open Network Stream", enter "rtsp://192.168.1.xxx/h265/ch01/main/av_stream", click "play", which starts RTSP streaming.

Important reminder: The IP Address (e.g. the one used by the PC) of the RTSP streaming device must be on the same network segment as that of the encoding board. Otherwise, the RTSP streaming mode will not work.

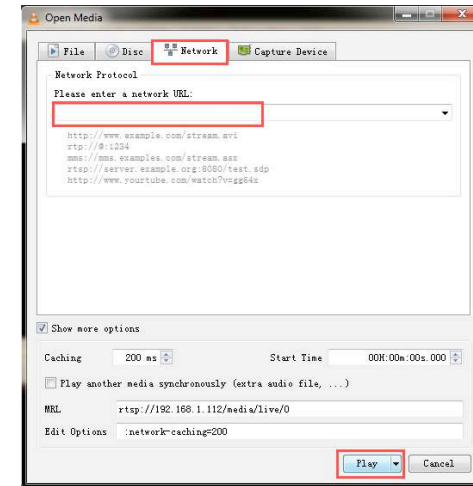
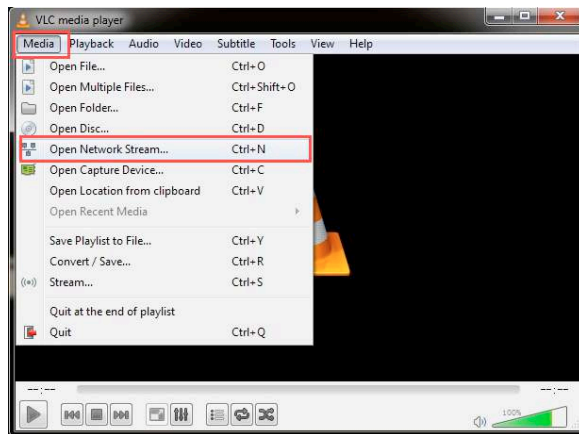

Extend the Transmission

Introduction to Panel Antenna

A panel antenna is a type of directional antenna, which can be used to extend the system's transmission range, but the trade-off is that the panel antenna has a transmission angle of 45 degrees.

Panel Antenna Usage

1. Mount the attached bracket on the panel antenna with screws.

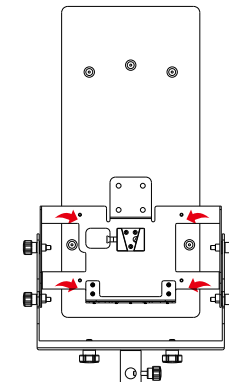

2. Fix the bracket on the tripod with screws.

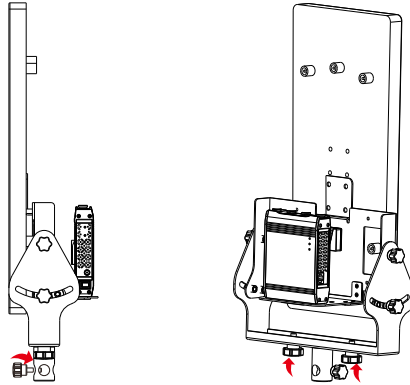

3. Attach the receiver to the bracket through the V-mount plate with the attached flexible cables.

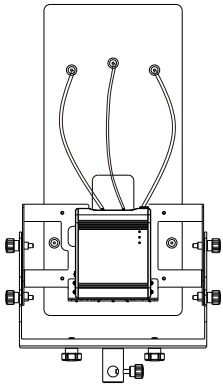

4. For the best result, the four transmitters need to move within 45° in front of the panel antenna.

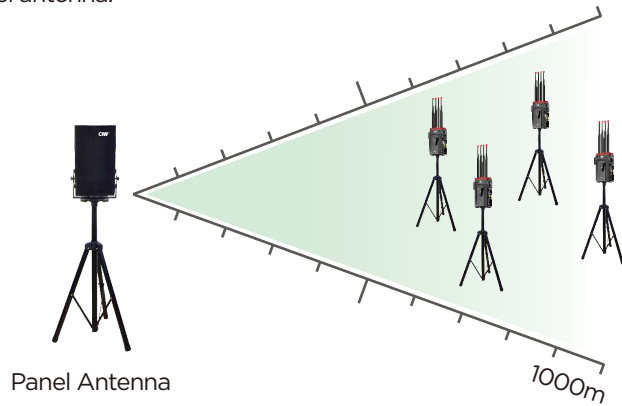

5. This system can transmit up to 1.5-2 kilometers when working with a panel antenna.

Video Parameter Settings

1. Please make sure that the computer and the receiver remain connected.
2. Set a fixed IP address for the computer and keep it with the system's IP address on the same network segment. (192.168.1.XXX).
3. Input the system's CODEC address into the corresponding box to enter the parameter settings page.

Configuration Menu

Version: 7106_4in1_V0.13_a **Software version**

IP ETHADDR
192.168.1.110 **Encoder IP address**

Video Bitrate
8000 Range (2000-15000) **Video bitrate**

SDI Audio Mode 0 1

RS422/232 RS422 RS232 **Switch between RS232 or RS422**

Serial Baud Rate 2400 9600 19200 38400 57600 115200 **Serial baud rate**

File Upload: 未选择任何文件 (Select A Local File) **Upgrade file selection**

save the configuration and then reboot...

Configuration save

Configuration Menu

Version: 3107_V0.13_a **Software version**

IP ETHADDR
192.168.1.212 **Decoder IP address**

RS422/232 RS422 RS232 **Switch between RS232 or RS422**

Serial Baud Rate 2400 9600 19200 38400 57600 115200 **Serial baud rate**

File Upload: 未选择任何文件 (Select A Local File) **Upgrade file selection**

save the configuration and then reboot...

Configuration save

Upgrade

1. The steps of firmware update are the same for both the transmitter and the receiver.
2. The back of the product labeled with the WiFi IP address and the codec board's IP address. The default IP addresses are as follows:

Transmitter	
Wi-Fi IP	192.168.1.201, 192.168.1.202, 192.168.1.203, 192.168.1.204
Encoder IP	192.168.1.111, 192.168.1.112, 192.168.1.113, 192.168.1.114

Receiver	
Wi-Fi IP	192.168.1.100
Decoder IP	192.168.1.211, 192.168.1.212, 192.168.1.213, 192.168.1.214

We are using the following diagram as an example. The system's operating mode, WiFi address, and encoder/decoder IP address are clearly shown.

Mode:STA

WiFi IP:192.168.1.201

Decode IP:192.168.1.111

Connect the computer to the receiver's LAN port. Open the browser and input the WiFi IP address into the address box to enter the login page.

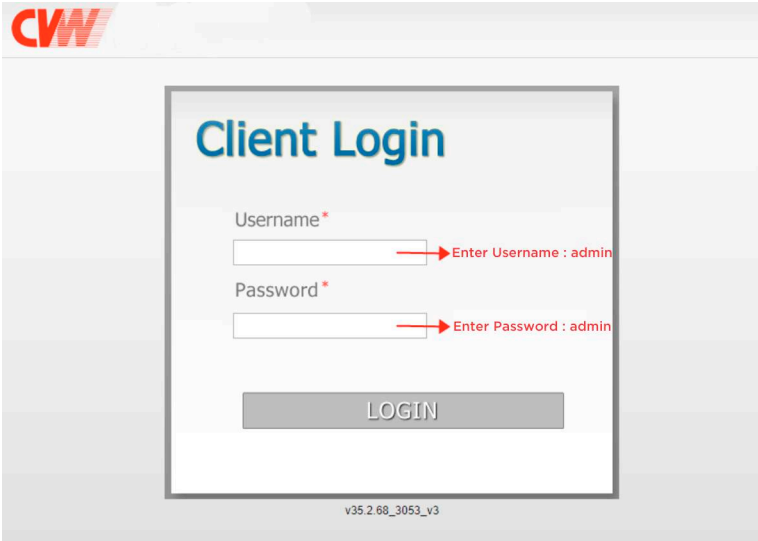

Once you have logged in successfully, will the WiFi parameter settings page.



Select the "Upgrade" option in the "System" box.

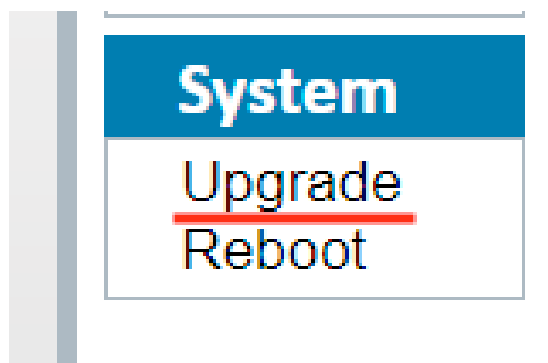

On the "Upgrade" settings page, you can upgrade the system's WiFi module software.

- 1: Select the latest software package.
- 2: Click to upgrade.

SYSTEM - UPGRADE

Choose a file:

选择文件 未选择任何文件

①

Upgrade

②

System Connectivity Diagram

In a point-to-point mode or RTSP mode, four video resources are sent to the four transmitters via HDMI or SDI port. Then they were received and sent by the receiver to the other monitoring devices. See the diagram below:

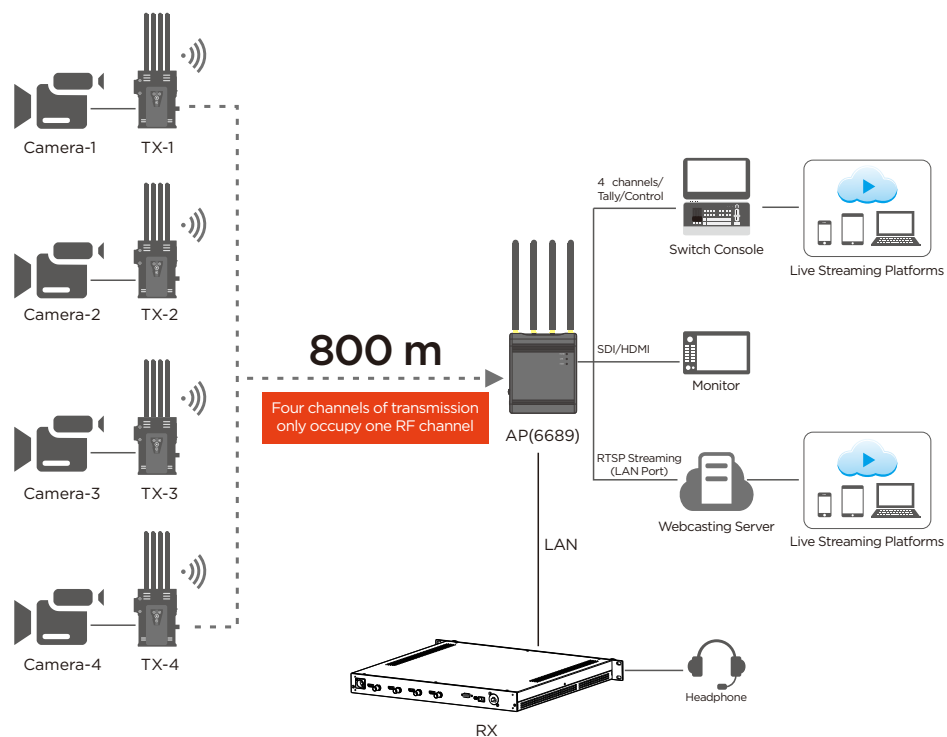

Product Specifications

Item	Transmitter: 7060	Receiver: 3066
Operating Frequency	5.1-5.8 GHz	
Antenna Mode	4*4 MIMO, 5dBi External Antenna	
Modulation Mode	OFDM	
Transmission Power	17dbm (per antenna)	Receiving Sensitivity: ≤-70dBm
EVM	≤-28dB	
Channel Bandwidth	40 MHz	
Wireless Standard	802.11n	
Network Encryption	WPA2/WPS	
Network Mode	Point-to-Point private protocol, RTSP protocol	
Transmission Distance	800 m/2600 ft (LoS)	
Transmission Delay	70ms	
Pairing Function	Supports pairing	
HDMI Protocol	Supports HDMI 1.4	
Video Resolution	1080P 23.98/24/25/29.97/30/50/59.94/60, 1080i 50/59.94/60 720P 50/59.94/60	
Audio Format	AAC	
Video Compression Format	H.265	
Remote Control	RS232/RS422	
IO Port Signal Return	Supports Tally signal return	
Interface	SDI input*1; HDMI input*1; Tally output*1; Lemo power connector*1; Antenna connector*4; Rocker power switch*1; OLED display screen*1; Button*3; NP-F970 battery slot*1	Db9 (Tally input)*1; Antenna connector*4; Lemo power connector*1; Network interface*1; Power button*1; Display screen*1; Functional button*3
Power Consumption	10W	20W
Operating Power Supply	DC 12V/2A	DC 12V/3A
Operating Voltage Range	7-17V	7-36V
Temperature Range	-10 - 50°C(Working);-20-80°C(Storage)	

Important Reminders

Installation height and interval distance

- Two conditions need to be met for a transmission distance of 800 meters.
First, orient each antenna to have a clear line of sight. Second, each channel needs to be set to 4Mbps bitstream.
- To achieve even better range performance, all the transmitters should be at a distance of 1.5-2 meters above the ground, while the receiver should be at least 2 meters above the ground.
- When multiple transmitters are used simultaneously, please ensure that they are at least 1 meter apart.
- When the receiver and other wireless devices are used simultaneously, please keep them at least 2 meters apart to prevent possible interference.

Gain Mode

You can set LNA at low gain mode in a wide-open line-of-sight environment with a distance of 300 meters distance. You can set the LNA at high gain mode when you want to transmit a signal through walls and far away from 300 meters

Channel Settings

- 1) When one system is in use, it is recommended to set the channel at CH5-CH9. Because in most Wi-Fi coverage environments, the high and low frequency is mostly used, while somewhere between is rarely used. The middle frequencies have low occupancy rates, which effectively avoids co-channel interference. Once the channel scanning function is enabled, it could quickly help to select the best possible channel from the available channel list.
- 2) When two systems are used simultaneously, the receivers must be placed at least 1 meter apart. Once the 80MHz operating mode is enabled, system one is set at CH5, and system two must be set at CH7, CH8, or CH9. It is recommended to keep them at least one channel apart. Once the channel scanning function is enabled, it could quickly help to select the best possible channel from the available channel list.
- 3) When multiple systems are used simultaneously, the receivers must be placed at least 1 meter apart. Once the 80MHz operating mode is enabled, system one is set at CH5, system two is set at CH7, and system three is at CH9. It is recommended to keep them at least one channel apart. Once the channel scanning function is enabled, it could quickly help to select the best possible channel from the available channel list.

Environmental Interference

The following environments will downgrade wireless transmission quality, resulting in image and audio misalignment (such as image freeze, noise).

- 1) Walls, large sheets of metal, and various instruments will downgrade wireless transmission. Try to avoid using this system in these environments.
- 2) Using this system in crowded areas, please place the transmitter and the receiver at a height of around 1.5 to 2 meters above the ground.
- 3) If 5GHz wireless devices are used nearby, these may also increase interference. It can be solved by switching to a different channel manually or automatically.
- 4) Please do not place this system in a metal container environment, because it will downgrade wireless transmission. If it is unavoidable, please ensure that each antenna has a clear line of sight.

Cable Connection

- 1) Please do not hot plug the HDMI cable of the powered system during use.
- 2) Please connect the transmitter to the video source with an HDMI cable firstly. Once the receiver and the monitor are connected, then you can switch them on.

Installation of Product and Antenna

- 1) When installing the magic arm, please fix the transmitter in a direction you want, then twist the magic arm to fix it on the camera. If you rotate the transmitter to fix it, the magic arm will not be easily demounted from the transmitter.
- 2) Please install the antennas before powering on the system.
- 3) To achieve even better range performance, please arrange the antennas to be fan-shaped and ensure each has a clear line of sight.

Battery Duration

Take the NPF-970 battery for example, a transmitter with 12W of power consumption, it will last about 3-4.5 hours.

Important reminder: Depending on the specific usage, the values may vary slightly.

Troubleshooting

Problems	Solutions
The transmitter and receiver are unable to establish a connection	<ol style="list-style-type: none">1) In short-distance situations, please ensure that the transmitter and receiver's antennas are already fully installed, then you must place them 5 meters apart. With LNA mode being set at low gain mode, (OLED screen displays the letter "L", meaning it is in low gain mode) and when multiple transmitters are used simultaneously, please ensure that the transmitters are at least 1 meter apart.2) In long-distance situations, the transmitter is set up on a camera or handle, it should be set up at 1.5-2 meters above the ground, and the cameraman's body should not obstruct the antenna's cylinder. The receiver should be set up at least 2 meters above the ground. The transmission is optimal when the antennas are arranged to be fan-shaped and have a clear line of sight. With LNA mode being set at high gain mode (OLED screen does not display the letter "L", meaning it is in high gain mode) and when multiple transmitters are used simultaneously, please ensure that the transmitters are at least 2 meters apart.
A black screen is displayed on the monitor via receiver output	Suppose the monitor displays a black screen through receiver output after switching the video source's video resolution. Please unplug and plug the transmitter or receiver's HDMI cable. If unplugging and plugging an HDMI cable does not make the system work normally, please restart the transmitter and receiver.

Problems	Solutions
The monitor displays a mosaic or lag	<ol style="list-style-type: none"> 1) Within a 300 meters range, LNA mode is set at low gain mode (OLED screen displays the letter "L", meaning that it is in low gain mode). 2) When multiple transmitters are used simultaneously, please ensure that the transmitters are at least 1 meter apart. 3) The transmitter is set up on a camera, it should be set up at 1.5-2 meters above the ground, and the cameraman's body should not obstruct the antennas. The receiver should be set up at least 2 meters above the ground, and the antennas are fan-shaped, and each has a clear line of sight. 4) The working channel is set between CH5-CH9. 5) In a range exceeding 300 meters or when needing to transmit a signal through walls, please set the transmitter and receiver to high gain mode. 6) If multiple systems are used simultaneously, please keep their receivers at least 2 meters apart. 7) If a wireless broadcasting and communication system is used on set, please keep the broadcast and communication host and the CVW receiver at least 2 meters apart.

Problems	Solutions
No video output when connecting a receiver to a switch console or monitor	Please confirm if the transmitter and receiver's OLED screen displays the signal icon and the word "VIDEO". If there is no signal icon, it indicates that the network is not connected. please refer to the first problem's solution of troubleshooting. If there is a signal icon, but the transmitter's OLED screen does not display the word "VIDEO", please check the video source and the connected SDI/HDMI cable. If the transmitter and receiver have a signal icon and a word "VIDEO", but the switch console displays nothing, please check the SDI/HDMI cable that is connected to the switch console, and change the camera's video output resolution to 1080i50 or 720p50, then test it. In addition, connect the receiver to other monitor with the SDI/HDMI cable to test them.
The display is flickering green when the receiver outputs video signal to the monitor	The HDMI cable has not been firmly plugged in the transmitter or receiver's HDMI port or has not been firmly plugged in the camera's HDMI port. Please unplug and plug the HDMI cable or change it to another HDMI cable.